

# NEXPAND

**CHILLED WATER** | ROW-BASED COOLING

TECHNICAL DATA SHEET

CW40 & CW60



# HIGH DENSITY APPLICATIONS demand high intensity, active cooling

Chilled water (CW) row-based active cooling is designed according to the latest data center technology requirements and part of the Nexpanse platform. The CW row-based cooling provides a smart, solid, secure, sustainable solution.



**SMART**  
UNLIMITED POSSIBILITIES



**SECURE**  
KEEP YOUR DATA SAFE



**SOLID**  
THE NEXT STEP IN RELIABILITY



**SUSTAINABLE**  
THE NEXT STEP IN ENERGY EFFICIENCY

The amount of power used by each data center rack continues to increase. The rapid development and increased usage of digital transformation technologies translates into a requirement for higher density computing environments, and the essential data center infrastructure to support them. Artificial intelligence, big data analytics, machine learning, research and many other high performance computing (HPC) applications are placing new demands on the data center. Computing densities are increasing and this requires a corresponding improvement in data center cooling solutions.

Minkels is addressing this need for high density, high intensity cooling by adding a Chilled Water (CW) option to its Nexpanse row-based Active Cooling portfolio.

**The 40 and 60 kW models bring all the benefits of row-based cooling to the high density computing environment:**

- Cooling equipment is close to the heat source
- Shortening the airflow path, thereby decreasing power consumption of the fan units
- Providing a fast, dynamic response of the coolers to changing heat densities.
- Sustainability is at the forefront of the Nexpanse row-based cooling solutions.

The CW cooling models can be deployed between cabinets, or bayed to a single cabinet and offer a flexible architecture – the models can be used as part of a row of cabinets, or on a one cabinet to one cooler ratio or, for very high density applications, two coolers for one cabinet.

The increasing importance of intelligent automation technologies to help manage the data center environment is reflected in the CW unit's range of communications options, based on state of the art Carel hardware:

- Serial communication with RS485 comes as standard
- Ethernet communication options (SNMPv2c, BACNET, MODBUS TCP/IP) are available to facilitate Building Management System (BMS) connectivity.
- Up to 16 DX units can be connected in a LAN network with a maximum of 8 subgroups to work together in a functional manner (e.g. cooler rotation).



## AIRFLOWS

Additionally, the CW units can be used as part of either an open loop (hot or cold) aisle containment system, or without aisle containment – closed loop; come with a dual power supply; and can be fully integrated with both Minkels Nexpanse cabinets and containment solutions.

### Closed loop solution

In a closed loop solution, the indoor unit's airflows are directly guided into the adjacent 19-inch cabinets. During this process, the indoor unit extracts the hot air directly from the IT-equipment and, as cold air, guides this back to the front. No exchange of air in the room in which the setup is located takes place. The system enables you to divide the cooling capacity over several cabinets.

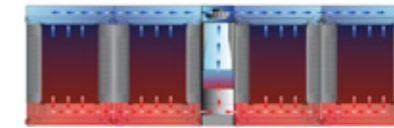

### Open loop solution

In an open loop solution, the cooling air is brought directly into the room outside of the cabinets. The module extracts the hot air from the room (hot aisle) and, as cold air, guides this back to the front (cold aisle) of the cabinet. For an optimal result, it is recommended to apply the Nexpanse aisle containment system when using an open loop solution.

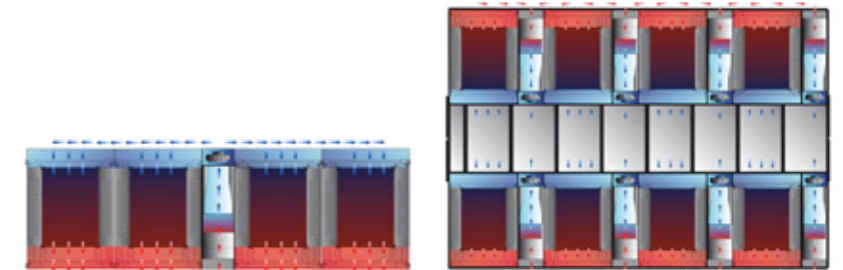

### Hot and Cold Aisle Containment with row-based active cooling

The Nexpanse cooling portfolio is perfectly compatible with industry standard hot-aisle and cold-aisle cooling typologies. Depending on customer specific needs either cooling strategy can be chosen and the corresponding cooling, cabinets and containment solution shall be designed and delivered as such.

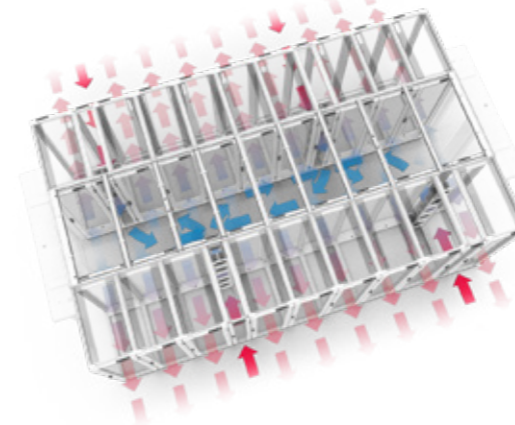

Cold aisle containment

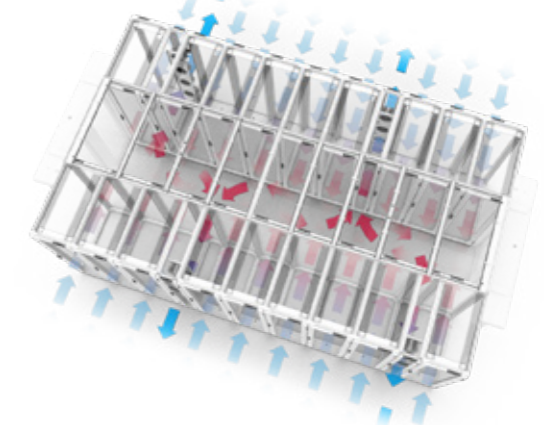

Hot aisle containment



# NEXPAND

## CHILLED WATER | ROW-BASED COOLING Features and benefits

### TOP AND BOTTOM PIPING CONNECTIONS

■ Connections for piping may enter the cooler from either the top or bottom of the unit. To facilitate this, all versions of the CW40 and CW60 accommodate top and bottom piping entry into the cooler. Also included on top and bottom are cable throughputs for connectivity, power and condensate discharge.

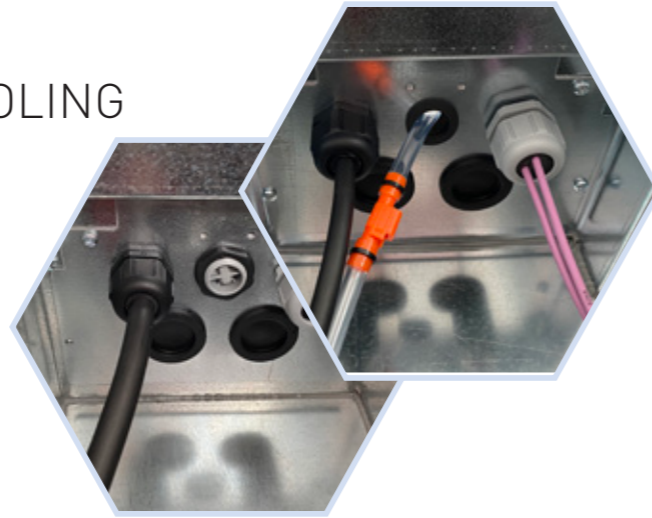

### DISPLAY

■ The display is placed at eyesight and is seamlessly integrated in the perforated or blind doors. The latter depends on the chosen cooling configuration. It enables reading the most important values for the cooling performance, such as cold and hot aisle temperatures as well as fan speed and the degree of opening of the water valve. The standard display comes with buttons to navigate through the controller software. The display can be upgraded with a touch screen display for a more premium look and feel of the cooling solution.



### ADVANCED CONTROL & MONITORING

■ To make sure you always know how the cooler is performing these are equipped with remote monitoring possibilities. Modbus RTU is standardly available as well as digital in- and outputs. This will allow you to monitor and control a vast number of business-critical parameters. Please review the list of options for more possibilities regarding remote monitoring & control.



*CW40 - closed loop configuration*



### HOT SWAPPABLE FANS

■ The coolers are equipped with hot-swappable fans. To minimize possible downtime due to fan failure, this feature enables swift and safe replacement of the fans. The unit does not need to be turned off to replace the fan(s), so the issue of a faulty fan can be resolved in a matter of minutes.

### EC FAN TECHNOLOGY

■ The fans are all equipped with EC fan technology. The benefits are an extended lifetime and a significant increase in the energy efficiency of the unit. Also, the fans are equipped with emergency speed functions. This means that even with controller downtime the fans are still running.

### NEXPAND FRAME

■ The cooling technology is fully integrated in a Nexpan frame. In this way you benefit from the same look & feel throughout your white space solution. Baying to adjacent cabinets is done in the exact same way as baying IT cabinets.

### SECURITY

■ As the Coolers are based on the Nexpan platform the front and rear closure is the same as with the standard IT cabinets. Apart from keeping the same look & feel it also enables the use of the same mechanical locking possibilities as with our range of IT cabinets. With this we ensure the highest level of security possible.

### HYDROPHILIC COILS AND INTEGRATED FLOAT SWITCH

■ As a standard all our models feature heat exchangers with Hydrophilic treatment. This special coating facilitates the condensate discharge towards the drip tray which is placed below the heat exchanger. The purpose of the drip tray is to collect and dissipate any condensation that may occur during operation. As an extra security feature each cooler is standardly equipped with a float switch installed in the drip tray. The purpose of the float switch is to sense when a maximum level of condensate is reached. When activated, it shall give a Flooding Alarm. If this alarm occurs, it may indicate a blocked condensate discharge and/or excessive condensation. Our specialist will always offer a solution that works with 100% of sensible cooling capacity. However, in the rare cases condensate might occur it is re-assuring this is properly taken care of.

### DUAL POWER FEED

■ To ensure your cooling system remains up and running even after power outage of the main feed we have standardly integrated a dual power feed that automatically switches to the redundant power feed.



*CW60 - open loop configuration*

### SLIDE-OUT ELECTRICAL BOX

■ For the CW40 cooler, which is 300mm wide, the electrical box is designed to take up as little space as possible without interfering with air distribution over the whole working height of the unit. To achieve this, without affecting accessibility during the initial start-up and unscheduled maintenance operations, a sliding drawer version has been created. This design also prevents tangling of the wiring whilst sliding.



# NEXPAND

## CHILLED WATER | ROW-BASED COOLING

### Options

You can expand your CW cooler with various options. Find the possibilities below

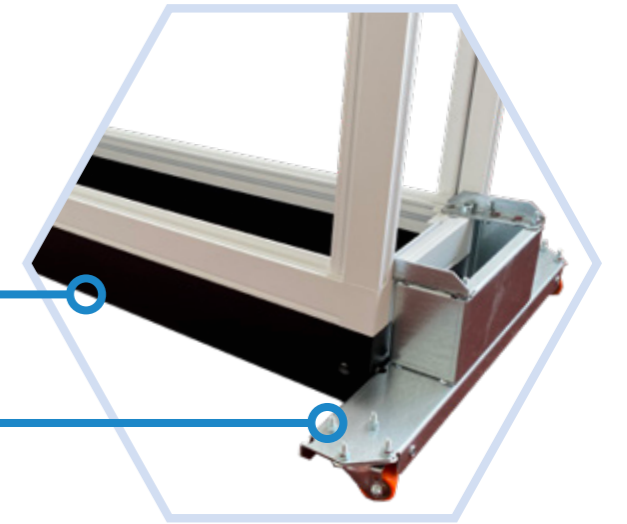
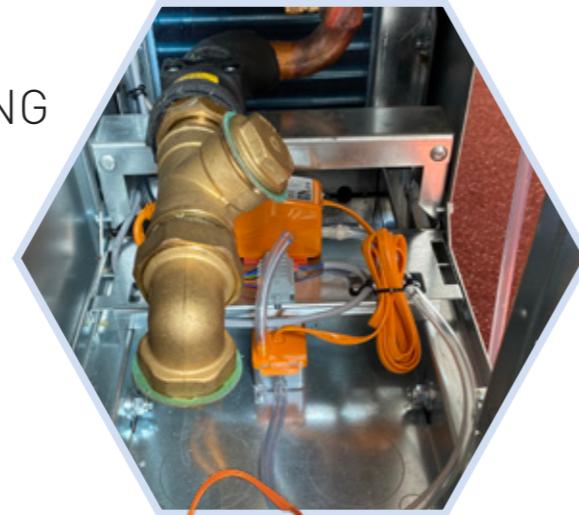

#### BASE-SET 100MM

■ When there are requirements when it comes to piping work and/or cabling underneath the cooler, a base-set which extends the height with 100mm can be deployed. The base-set is also available for our standard range of IT cabinets so the entire set-up including cooling can be perfectly aligned and have the same look & feel.

#### TRANSPORT TOOL

■ Safety and ease of transportation are important factors especially in the initial stages of the cooler deployment. To ensure a safe placement of the coolers which, due to their weight and form factor, have a risk of tipping over, we have developed a dedicated transport tool. The tool is easy to mount and remove and it also improves the maneuverability of the cooler in the white space area.

#### CONDENSATE PUMP

■ When condensate discharge via gravity is not possible because of a concrete floor or other limitations, a condensate pump can be chosen. This will get rid of any condensate that may occur from the drip tray where it is collected from the heat exchanger.



#### TOUCH SCREEN

■ To upgrade your cooler for a more user friendly and high-tech feeling a touch screen display can be chosen. It utilizes the same cut-out in the door as the standard display so even retrofit upgrades are an easy job.

#### ADVANCED MONITORING

■ When monitoring through other communications protocols is a need, we can support this by upgrading with the pCOWeb card. It features communication with SNMPv2c, BACNET, Modbus over TCP/IP and it is equipped with an integrated webserver.

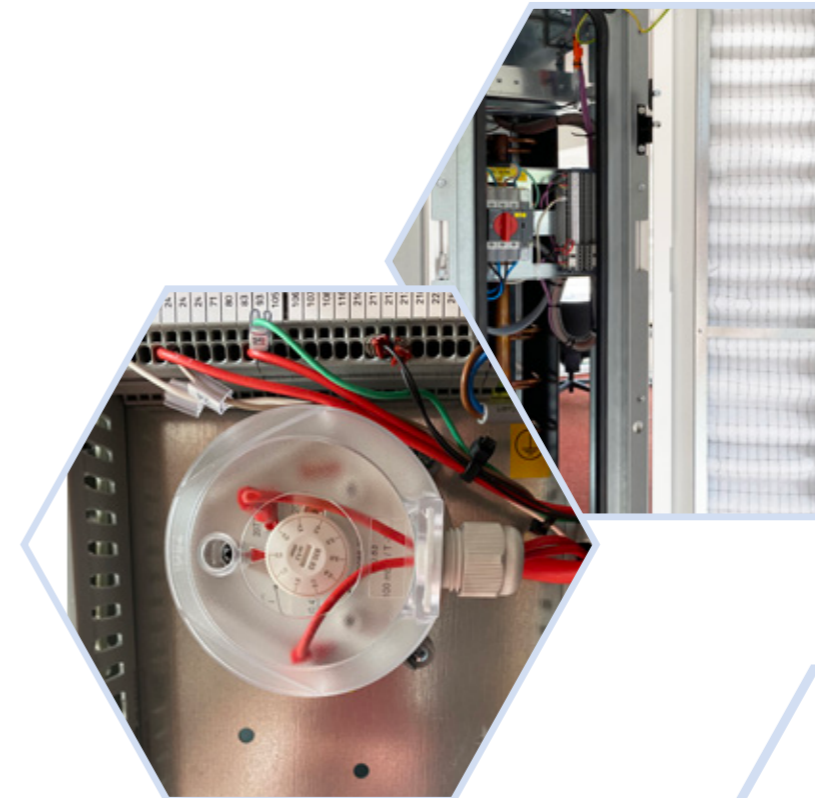

#### FILTER SET G4 + DIFFERENTIAL PRESSURE SENSOR

■ To collect potential dust and particles we can offer a filter set class G4. A differential pressure sensor will detect at a pre-defined threshold when it reaches the maximum pressure. This will indicate a clogged filter so it can be replaced at the next service interval or prior to that.

#### 3-WAY VALVE

■ As a standard 2-way valves are integrated in the hydraulics circuit of the coolers. The 2-way valves are meant for cooling infrastructures with variable flow. As an alternative, in the case of systems with a fixed flow, we can offer our hydraulics circuit with a 3-way valve.



# NEXPAND

## CHILLED WATER | ROW-BASED COOLING Performance and specifications



CW40 - open loop configuration

CW60 - open loop configuration



CW40 - open loop configuration

CW60 - open loop configuration

GENERAL SPECIFICATIONS			
		CW40	CW60
Number of Fans	-	5	2
Fan type	-	EC Fans, brushless with integrated electronic	
Weight	kg	220	270
Water connections	-	1 1/4"	1 1/2"
Valve type	-	2-way, Danfoss / VRG (3-way optional)	
PN	-	16	
Refrigerant	-	Water / Water-Glycol	
Lp @ Nominal rpm ; dist.= 2 m Q=2	dB(A)	65	70
Weight	kg	145	255
Power supply	V/ph/Hz	230 / 1 / 50	400 / 3+N / 50
Electrical connections	-	Screw connectors	

INLET/OUTLET WATER TEMPERATURE 12-18					
		CW40		CW60	
Return air conditions (°C; RH)		40°C; 20%	35°C; 20%	40°C; 20%	35°C; 20%
Cooling capacity	kW	38.95	31.38	65.01	52.26
Net. Sensible Cooling Capacity	kW	38.23	30.66	63.52	50.77
SHR	-	1	1	1	1
Air flow	m3/hr	5300	5300	9000	9000
Water flow	l/h	5587	4501	9325	7497
Water pressure drop	kPa	100.1	65.0	127	82.1
Fans absorbed power	kW	0.72	0.72	1.49	1.49
Fans absorbed current	A	3.5	3.5	2.4	2.4
EER	-	54.1	43.6	43.6	35.1

INLET/OUTLET WATER TEMPERATURE 15-21					
		CW40		CW60	
Return air conditions (°C; RH)		40°C; 20%	35°C; 20%	40°C; 20%	35°C; 20%
Cooling capacity	kW	34.81	26.66	56.93	44.35
Net. Sensible Cooling Capacity	kW	34.09	25.94	55.44	42.86
SHR	-	1	1	1	1
Air flow	m3/hr	5300	5300	9000	9000
Water flow	l/h	4999	3828	8176	6370
Water pressure drop	kPa	80.1	47.0	97.6	59.3
Fans absorbed power	kW	0.72	0.72	1.49	1.49
Fans absorbed current	A	3.5	3.5	2.4	2.4
EER	-	48.3	37.0	38.2	29.8



# NEXPAND

## CHILLED WATER | ROW-BASED COOLING CW 40 - General dimensions

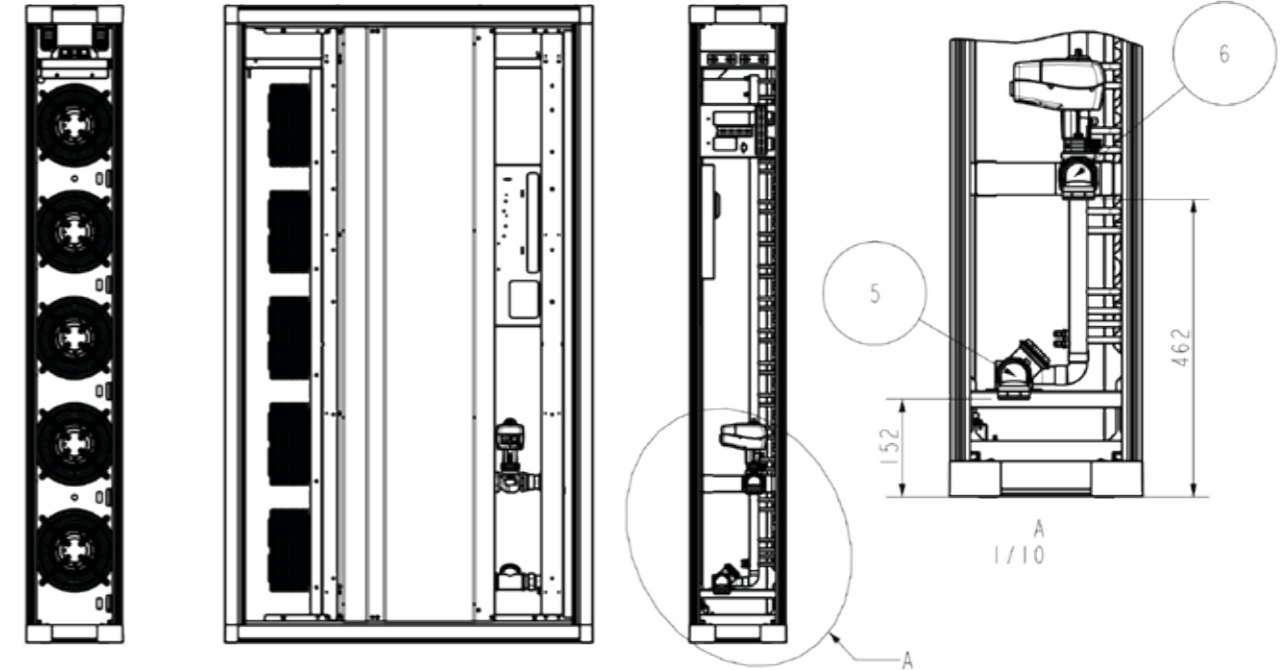
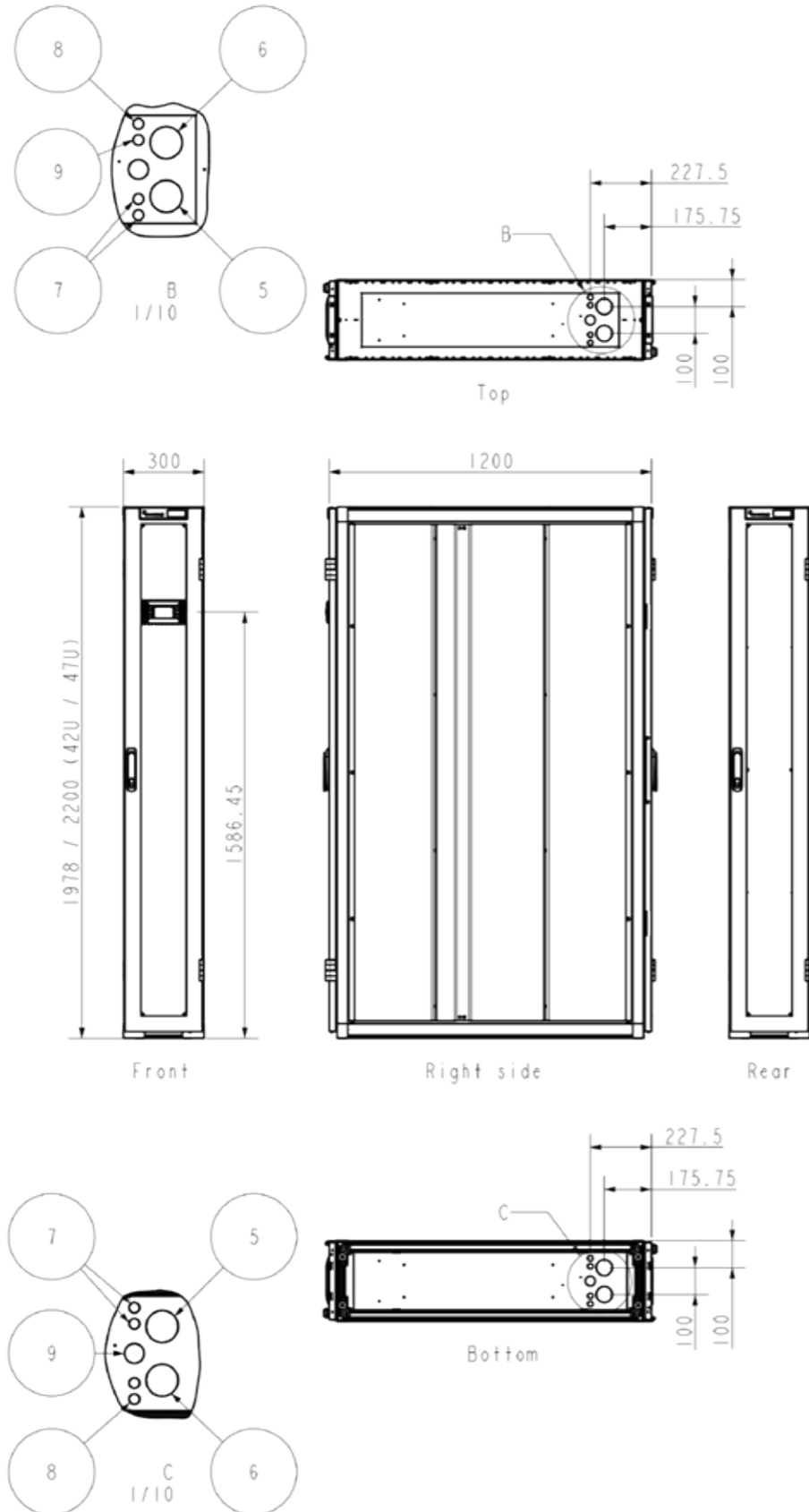

#	Description
1	Removable front door
2	Removable rear door
3	Display
4	Removable side panel
5	Cooling water inlet (1"1/4 gas female)
6	Cooling water outlet (1"1/4 gas female)
7	Power supply (A & B feed)
8	Data cables
9	Condensate drain

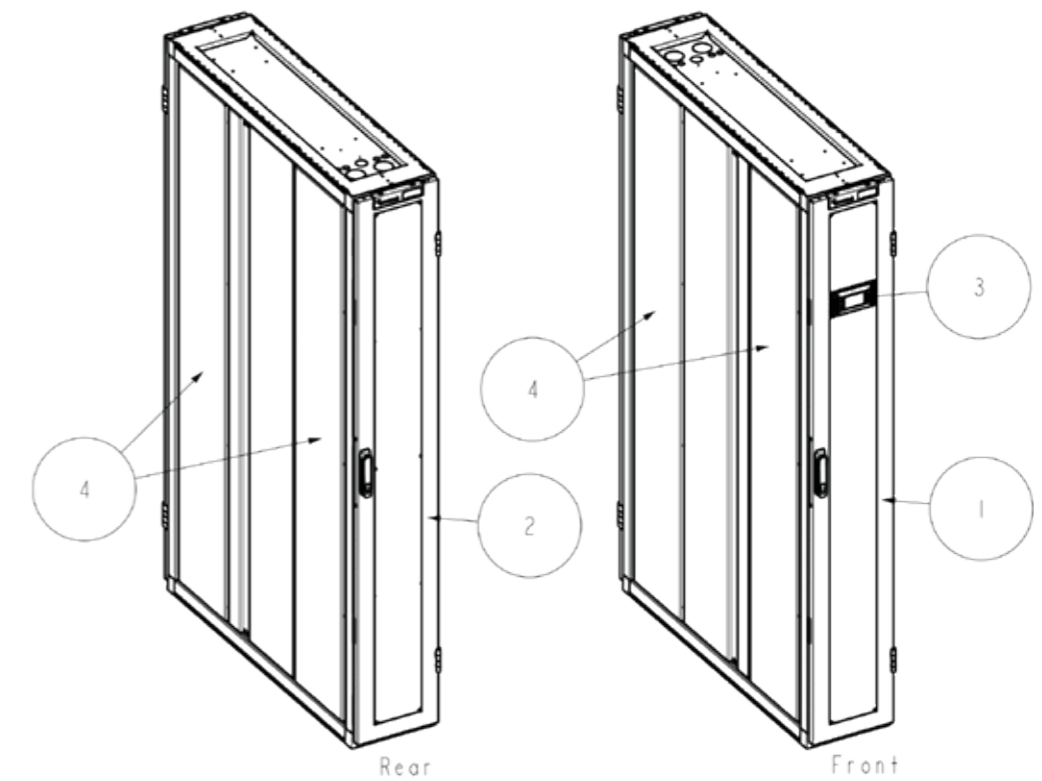

# NEXPAND

CHILLED WATER | ROW-BASED COOLING

## CW40 - Transport tool

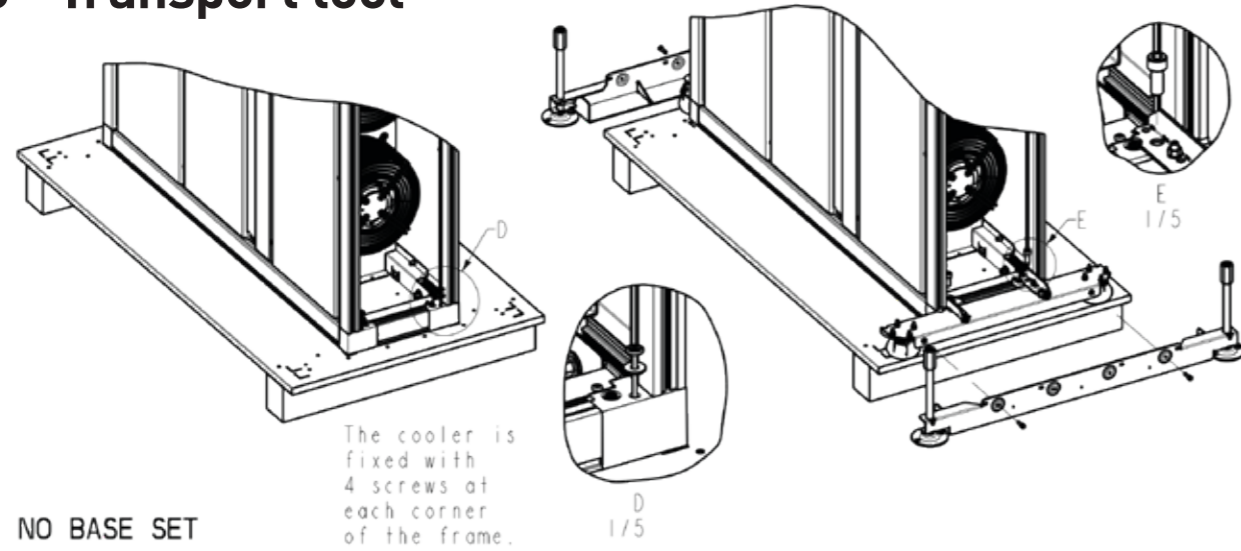

NO BASE SET

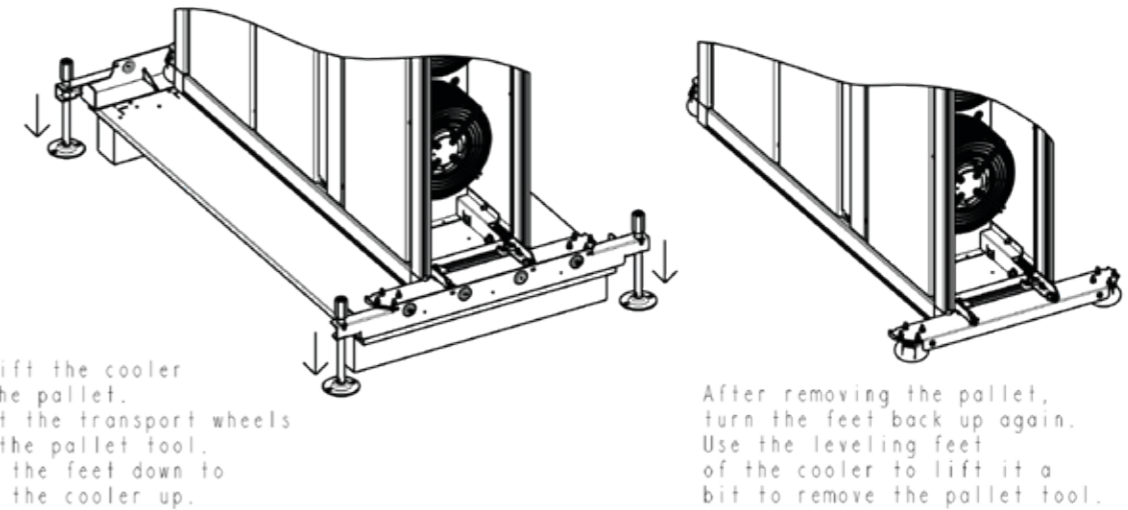

BASE SET

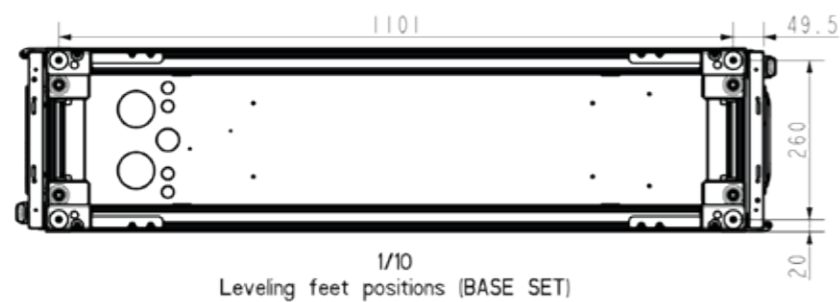
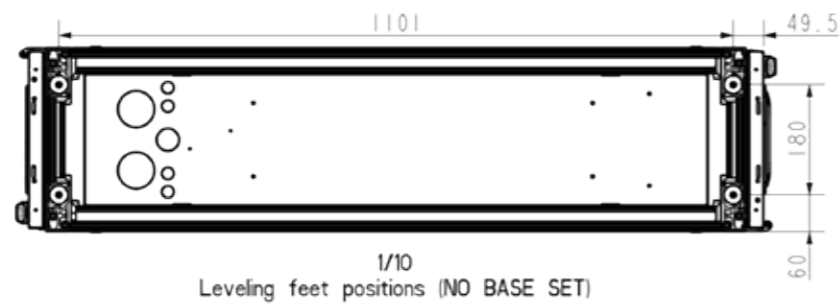
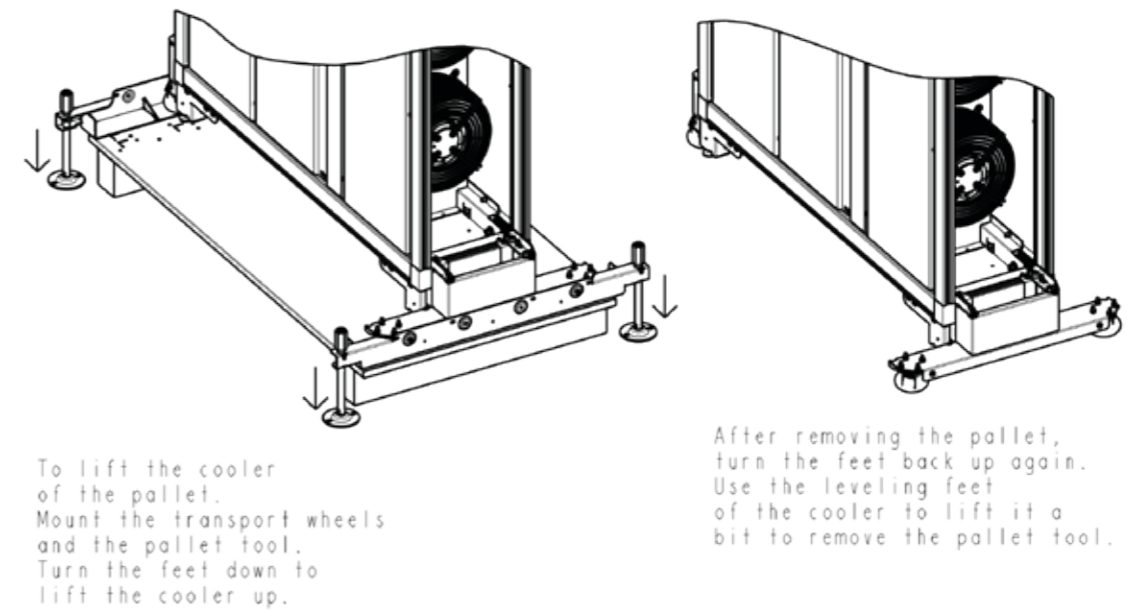
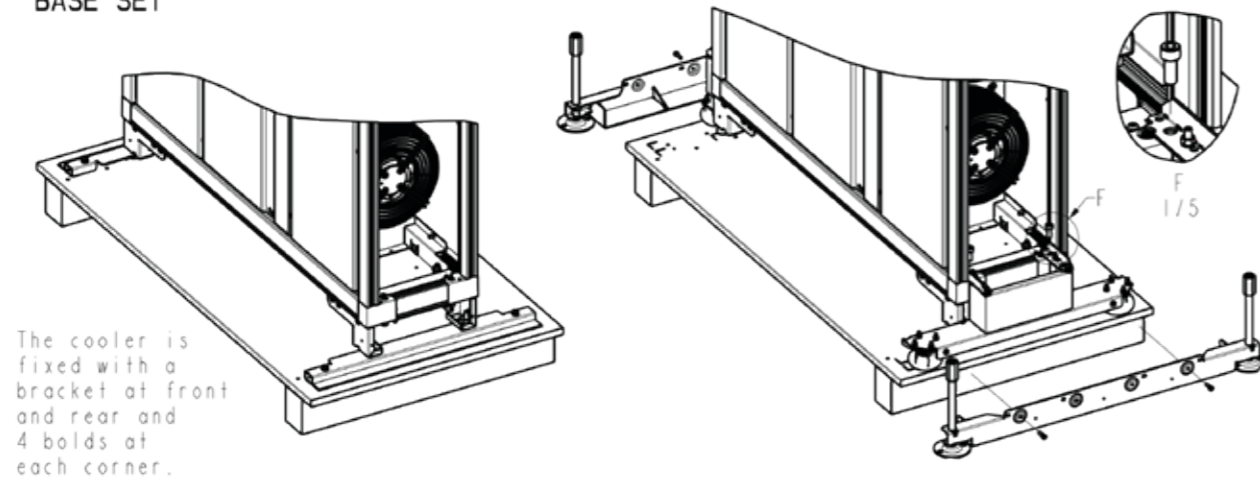

Outer dimensions incl. packaging

	No Base set		Base set	
	42U	47U	42U	47U
Height	2092	2314	2192	2414
Width	680	680	680	680
Depth	1280	1280	1280	1280

# NEXPAND

## CHILLED WATER | ROW-BASED COOLING CW60 - General dimensions

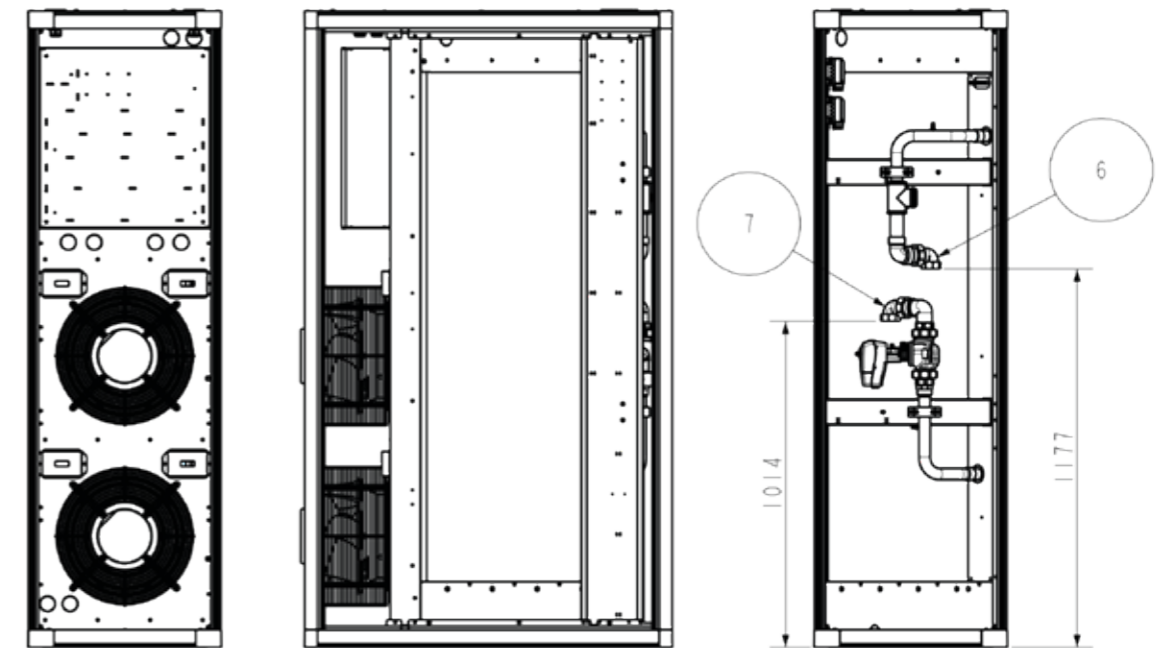
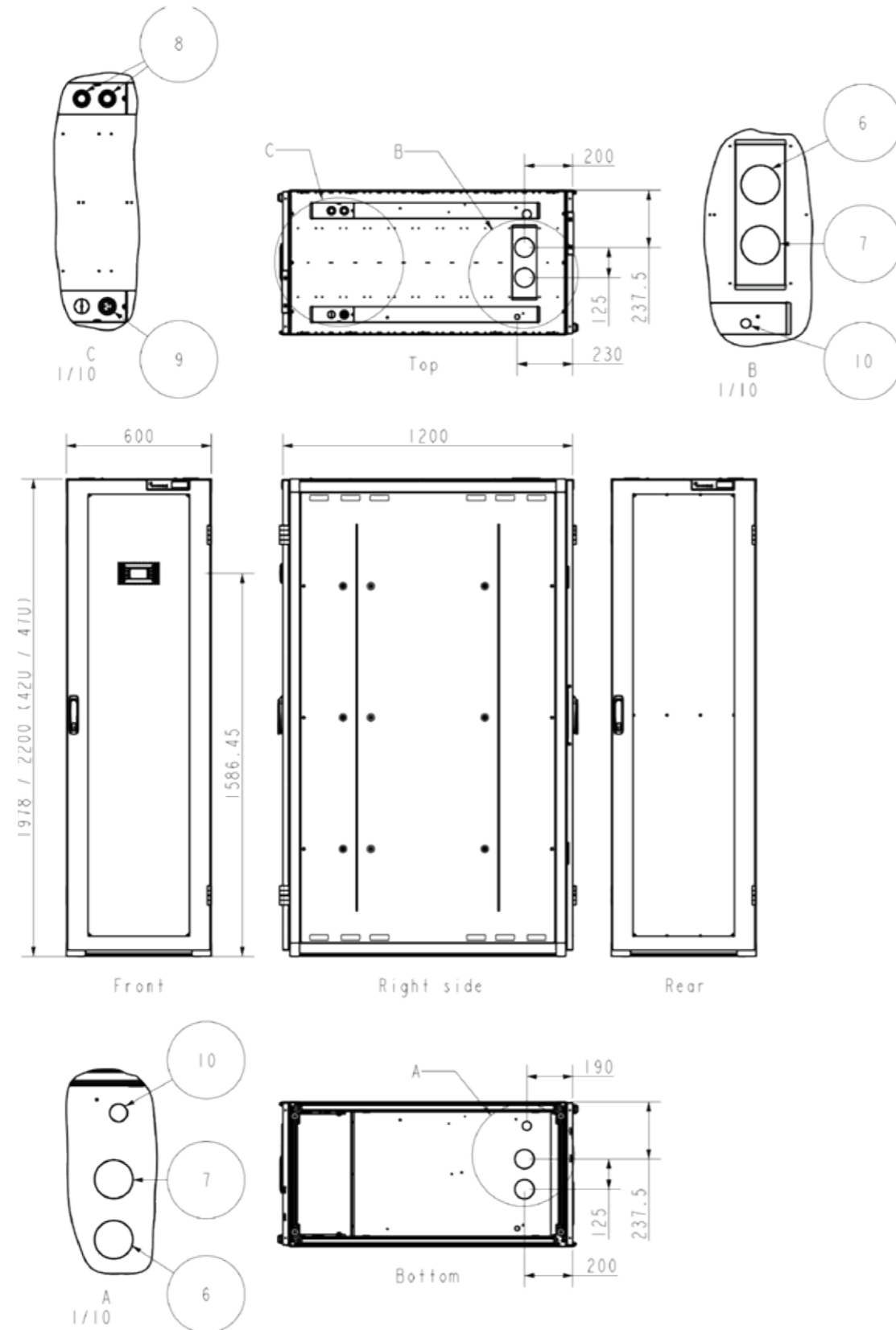

#	Description
1	Removable front door
2	Removable rear door
3	Display
4	Removable left side panel
5	Removable right side panel
6	Cooling water inlet (1"1/2 gas female)
7	Cooling water outlet (1"1/2 gas female)
8	Power supply (A & B feed)
9	Data cables
10	Condensate drain

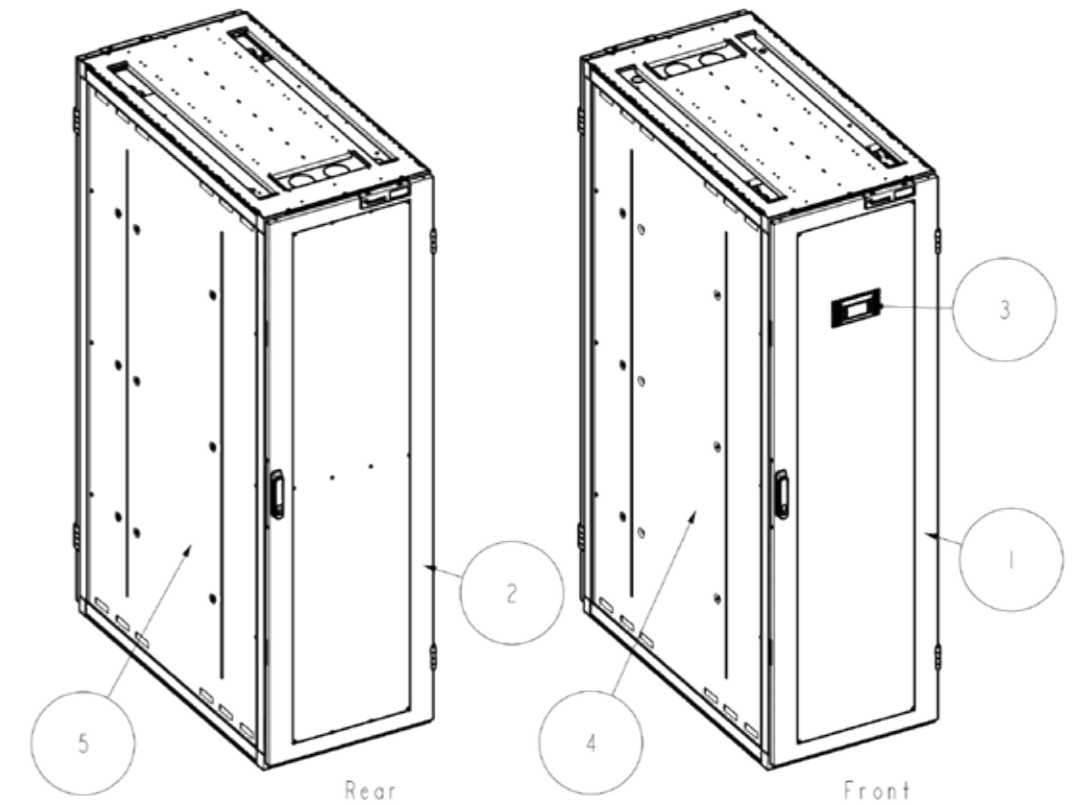



# NEXPAND

CHILLED WATER | ROW-BASED COOLING

## CW60 - Transport tool

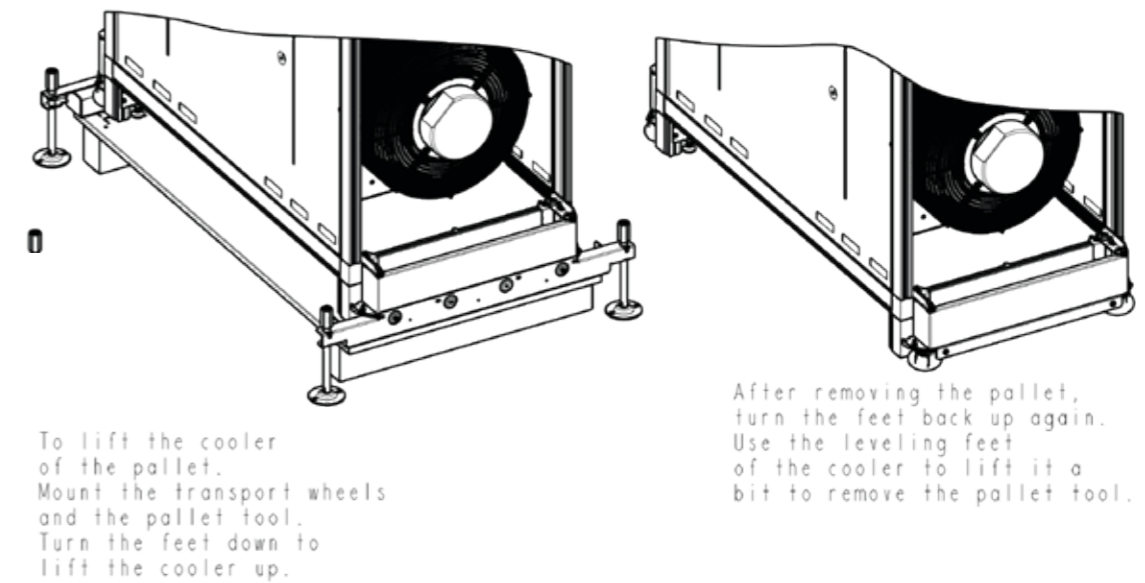
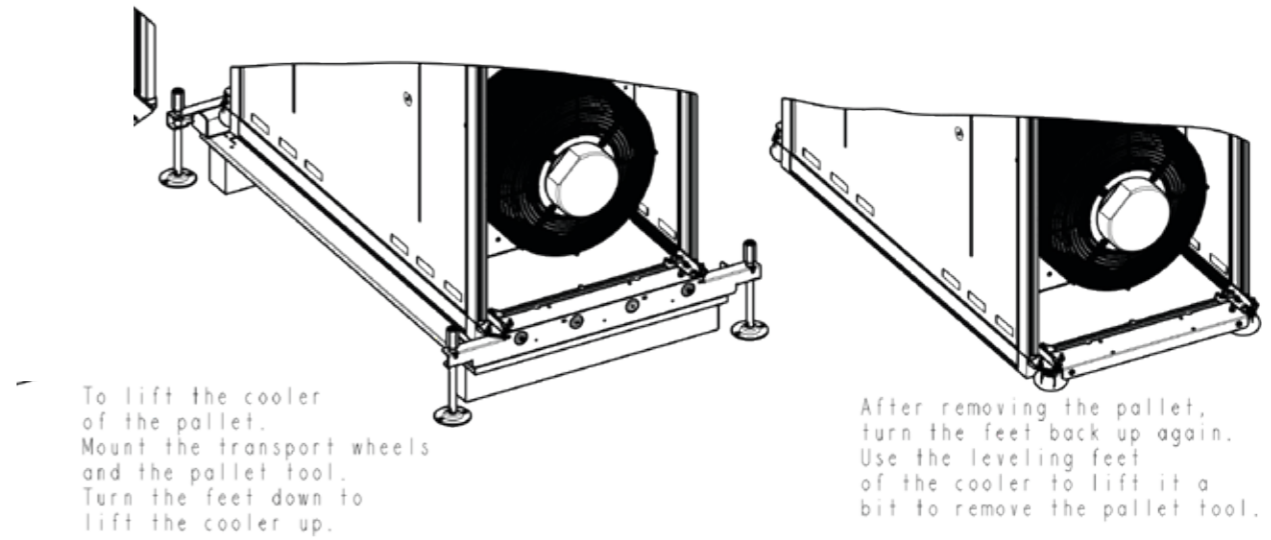
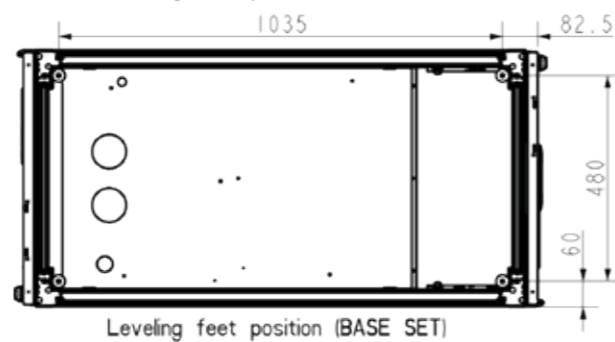
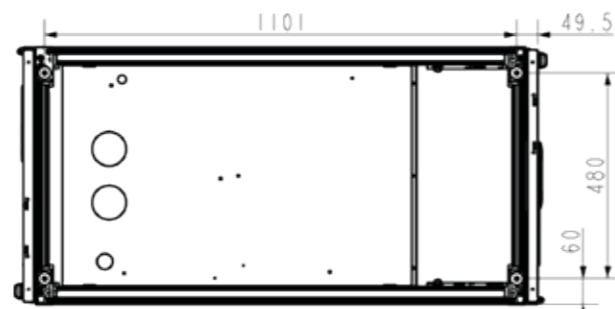
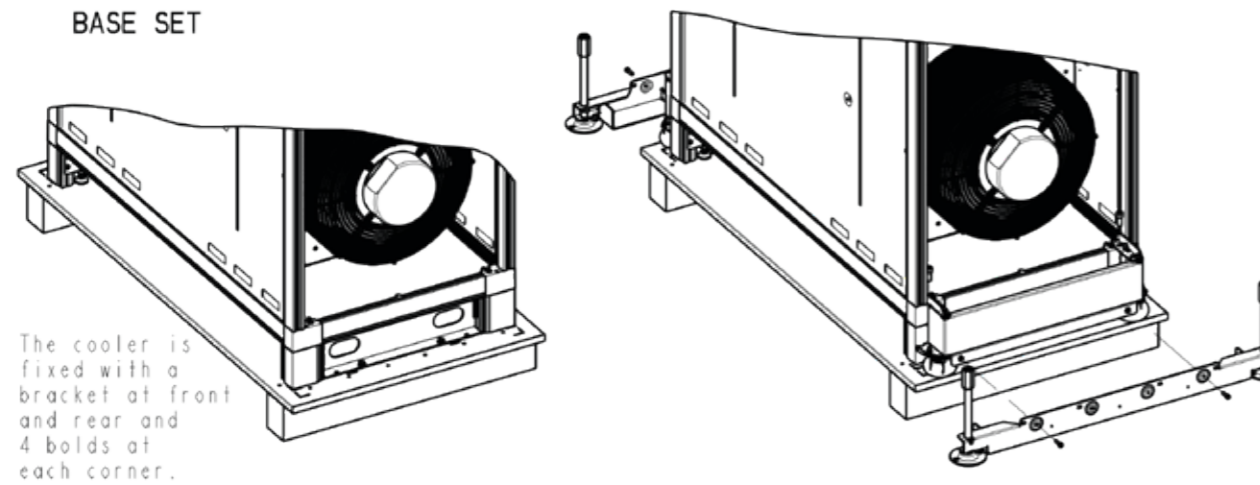
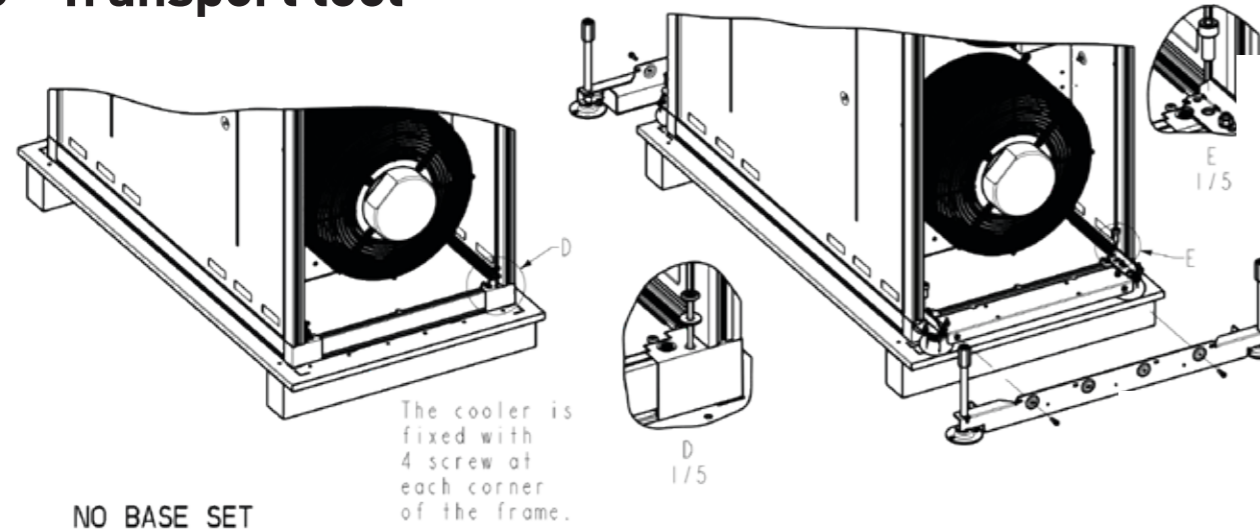

Outer dimensions incl. packaging

	No Base set		Base set	
	42U	47U	42U	47U
Height	2092	2314	2192	2414
Width	680	680	680	680
Depth	1280	1280	1280	1280



## FOLLOW US ON

-  [minkels.com](http://minkels.com)
-  [youtube.com/c/minkelshq](https://youtube.com/c/minkelshq)
-  [twitter.com/minkels\\_hq](https://twitter.com/minkels_hq)
-  [facebook.com/minkels](https://facebook.com/minkels)
-  [linkedin.com/company/minkels](https://linkedin.com/company/minkels)



### MINKELS HEADQUARTERS & INTERNATIONAL

Eisenhowerweg 12  
P.O. Box 28  
5460 AA Veghel  
t. +31 (0)413 311 100  
[info@minkels.com](mailto:info@minkels.com)