

# Keor FLEX 1200 kVA

## Three-phase modular UPS system

Cat.No : 3 113 90 - 9 000 91



CONTENT	Page
1. Characteristics .....	1
2. Range .....	1
3. Technical data .....	1
4. User interface .....	3
5. Standards and regulations .....	3
6. Other informations.....	3

### 1. CHARACTERISTICS

Keor FLEX is a modular UPS system, based on 100 kW hot swap power modules.

The system is totally front access for usage and maintenance, no space clearance is needed or lateral and rear side of the cabinet. Logic control is distributed in each power module.

Accordingly with needed configuration is possible to set up the following options:

- Grounding System TNC/TNS
- Embedded or Not Embedded Distribution switches
- Common or separated input for Rectifier and Bypass line
- Connection with Cable (Top or Bottom) or with Busbars
- Icw limiting option up to 100kA

#### ■ 1.1 Specific application

Ideal solution for IT and Data Centre applications. Suitable for generic critical application which needs power continuity

### 2. RANGE

Cat. No.	Description	Power	N. of installable Power Modules
9 000 91	UPS CABINET	1200KW	up to 12
3 113 90	POWER MODULE	100 KW	-

### 3. TECHNICAL DATA

#### ■ 3.1 General characteristics

Nominal power [kVA]	1200
Active power [kW]	1200
UPS Topology	ON LINE - Double Conversion VFI-SS-111
Architecture of the UPS	Modular
In/Out phase Configuration	3Ph+N+PE
Neutral	Passing straight from input to output
Neutral grounding system compatibility	TNC,TNS
Bypass type	Static bypass switch + maintenance bypass switch
Transfer time	No Break
Parallel	Yes up to 4 units

Cold start	Yes
Efficiency (AC/ AC) [%]	
@25% load	98.6
@50% load	98.4
@75% load	98.0
@100% load	97.1
Efficiency (AC / AC) (Eco Mode)	99
Max Heat loss (VFI) [kW - BTU/h] (Fully charged battery)	30.7 kW - 104752 BTU/h
Max Heat loss (VFI) [kW - BTU/h] (Battery in charge@max charge current)	37.6 kW Battery recharge 240 kW - 128296 BTU/h

#### ■ 3.2 Input

Nominal voltage [V]	400
Voltage range[%]	+ /- 20
Frequency [Hz]	50/60
Input frequency range [%]	+/- 10%
THDlin [%] @100% load	<3%
Input Power Factor	>0.99
Nominal current absorbed from mains (at nominal load and battery charged) [A]	1805
Maximum current absorbed from mains (at nom. load, nom. voltage and max. recharging current) [A]	2150

**3. TECHNICAL DATA (continued)**

**3.3 Output**

Nominal voltage [V]	380-400-415 (selectable)
Output Voltage Tolerance	
Balanced Load [%]	+/- 1
Unbalanced Load [%]	+/- 1
Output Frequency [Hz]	50/60
Output frequency tolerance Synchronized with Mains [Hz]	± 2 (adjustable)
Free Running tolerance [Hz]	+/- 0,01
Slew rate [Hz/s]	adjustable from 1 to 3 Hz/sec
THDv on nominal power (linear load) [%]	<1
THDv on nominal power (not linear load P.F.=1) [%]	<3
Nominal Output Current (@ Nominal Voutput) [A]	1740
Current Crest Factor	Up to 3
Overload capability:	
@125% Load	10 min
@150% Load	1 min
Short Circuit Current on battery run [A]	3 In- 40 ms

**3.4 Battery**

Type	VRLA – LION
DC poles	2 (Positive and Negative)
Nominal UPS Battery Voltage [Vdc]	420 min – 680 max
Minimum Discharge Voltage [Vdc]	420
Max Charging Current Power	20kW per module (at nominal input voltage)

**3.5 Bypass**

Nominal voltage [V]	380– 400 – 415 (selectable)
Voltage Range [%]	+/- 10
Frequency [Hz]	50 / 60 (selectable)
Frequency range [%]	+/- 10 (selectable)
Dedicated Input for the Bypass	Yes
Transfer time	Class 1 as per EN62040-3
Overload Capability [%]	
@125% Load	30 min
@200% Load	1 min
@1000% Load	100 ms
Static bypass peak current [kA]	65 kA peak - 60ms
Maximum I2t [A²s] [20 ms]	13.7 x 10 <sup>6</sup> A²s
Back feed protection	Internal and signal for external backfeed
External Manual bypass Interlock	Trapped key interlock optional

**3.6 HMI and cumunication**

Control panel	Touch Screen, Status light
Communication ports	SNMP TCP/IP adapter , ModBus / IP , 5 programmable dry contacts
Auxiliary signal	EPO, BackFeed, GenSet, External maintenance Bypass, Battery switch, Temperature Probe

**3.7 Enviromental specs**

Working temperature range [°C]	0 ÷ 40
Stock temperature range [°C]	-25 ÷ 55
Humidity range [%]	10% to 75% non-condensing
Maximun relative humidity at 20°C non-condensing [%]	up to 95
Maximum Altitude without derating	1000
Protection degree	IP20 (IP21 optional)
Noise level @ 1m [dBA]	77 @ 100 % load < 75 @ 50 % load

**3.8 Mechanical characteristics**

Cabinet Net Weight [kg]	2200
Cabinet Dimensions [WxHxDmm]	2230 x 2101 x 1262
Power module Net Weight [kg]	72.5
Power module Dimensions [WxHxDmm]	546 x 154.5 x 892.5
Bypass module Net Weight [kg]	26,5
Bypass module Dimensions [WxHxDmm]	298 x 248 x 614,5
Colour	White RAL9003 / RAL 9005
Distribution switches	Output, input bypass, manual bypass
Ventilation	Speed controlled fan
Thickness of Covers [mm]	Up to 1.5mm
Connections	Top busbar, top cable, bottom cable
Accessibility (Operations and Service)	Total front
Packaging	Carton Box on Pallet / sealed seabag + wooden Box (it depends on the destination)

**3.9 Block Diagram**

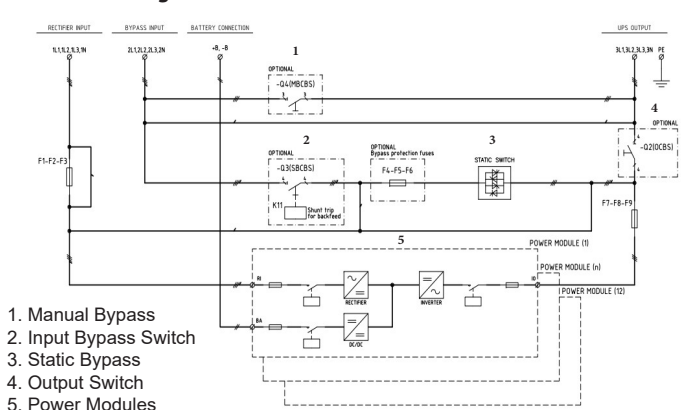

#### 4. USER INTERFACE

Keor FLEX is equipped with an innovative 10" touch screen user-friendly graphic user interface.

The display is capable of reading real-time data regarding working conditions, efficiency, consumption, load variations, as well as input / output power, current, voltage, etc.

<b>Input</b>	Current	RMS value Peak value Crest factor
	Voltage	Ph-N RMS value Ph-Ph RMS value Bypass line voltage
	Power	Nominal (VA) Active (W) Power factor Frequency
<b>Output</b>	Output current	RMS value Peak value Crest factor
	Voltage	Ph-N RMS value Ph-Ph RMS value
	Power	Nominal (VA) Active (W) Power factor Frequency
	<b>Batteries</b>	Voltage Capacity Current History data Residual capacity Charging status
<b>Miscellaneous</b>	Internal Temperature Fan Speed HV DC BUS voltage	
<b>Data Log.</b>	By-pass intervention Overheats Overloads Battery interventions Total discharge Events Alarms	

The UPS allows also the following settings by display:

<b>Output</b>	Voltage Frequency
<b>Input</b>	Enable freq. synchronizing
<b>By-pass</b>	Enabling Forced ECO Mode batteries

#### 5. STANDARDS AND REGULATIONS

The UPS Keor FLEX has the CE Mark accordingly with the EU Directives 2006 95 2004 108 and it comply with following standards

- EN 62040-1: General rules for electric safety
- EN 62040-2: Electromagnetic compatibility and immunity (EMC)
- EN 62040-3: Performances and testing rules



#### 6. OTHER INFORMATIONS



**Installation and maintenance manual:** mounting informations and maintenance guide available on e-catalogue

For further technical information, please contact Legrand technical support.  
 Unless otherwise indicated, data reported in this document refers exclusively to test conditions according to product standards.  
 For different conditions of use of the product, inside electrical equipment or in any different installation context, refer to the regulatory requirements of the equipment, local regulations and design specifications of the system.